

Hydrostatic Drive Diesel/LPG Trucks 8,000 - 10,000 lbs.



H40D/T
H45D/T
H50D/T

394 Series

Introduction

The new generation of heavy duty **H40, H45, and H50** forklifts, redefine the meaning of performance. Impressive productivity resulting from superb operator comfort combines with low fuel consumption and low maintenance costs for lowest total cost of ownership.

Operator Compartment

The spacious and ergonomic operator's compartment provides automobile-class comfort. Options include: Cab, heater and air conditioning. There is also abundant storage space. Instruments and switches are mounted in an overhead console, in view and within easy reach. Linde fingertip load control levers integrated in an adjustable armrest provide effortless response for precision control of all mast functions. Linde twin drive pedals allow fatigue-free, rapid and seamless changing of travel direction. Road shocks are absorbed by the unique resiliently mounted drive axle. Quiet running eliminates stress for the operator and surrounding environment, which, together with excellent all-around visibility contributes to the highest standards of safety in operation.

Chassis

Linde Protector Frame, the unitized structure

overhead guard and truck chassis, ensures optimum strength and safety. The enclosed chassis protects internal components from dust and dirt. Maintenance is simplified by the wide engine cover and additional access openings.

Engine

Quiet running diesel and LPG engines embody the most advanced technology. High torque, high fuel efficiency, and reduced exhaust emissions are hallmarks of these powerplants.

Hydrostatic Drive

Eliminates the need for clutch, gearbox and conventional brakes. The virtually maintenance-free Linde hydrostatic drive out performs conventional designs, particularly in extreme working conditions.

Electronics/Electrical

Smart Linde Truck Control (LTC) automatically adjusts engine speed to precisely match the hydraulic power demand for a specific task. Auto-diagnosis function simplifies and reduces maintenance times. Controller and electrical circuits are protected from moisture and dust using automotive sealant technology for optimum reliability.

Steering

Direct feed-back hydrostatic steering with compact ergonomic steering wheel for effortless and responsive control. The steering wheel height/angle is also adjustable.

Mast

Unique, top-mounted tilt cylinders ensure precision handling and control of the load. Residual capacities are increased through a wider range of lift heights. Slim mast profiles yield a clear view of the load and surroundings. The pivot points of the tilt cylinders and the mast are cushioned for shock and vibration abatement. An electronic tilt angle limiter cushions the tilt stroke.

Brakes

Three independent braking systems provide maximum operational safety. In normal operation, smooth, progressive, dynamic braking automatically occurs as the accelerator pedal is released. For rapid deceleration in emergencies, depression of the brake pedal initiates hydrostatic braking and actuates the oil immersed disc brakes on the front wheels. Fail-safe automatic application of the oil immersed brakes occurs when the engine is switched off.



Safety First

Specific safety features:

- Exemplary ergonomics
- Automatic, progressive, dynamic braking as drive pedal is released
- Automatic parking brake actuation when engine is switched off
- Oil immersed disc brakes for rapid deceleration in an emergency
- Low truck sound emissions, enable external warning signals to be heard
- Duplication of all electronic safety circuits
- Linde Protector Frame
- Excellent visibility
- Excellent residual capacity
- Lowering control valve
- Precision cornering and steering

Standard Equipment

- All items shown under safety
- Linde hydrostatic drive
- Finger tip Linde Load Control system (LLC)
- Linde twin directional control pedals
- Full suspension, variable adjustment comfort seat
- On-demand hydrostatic power steering
- Adjustable steering column
- High performance air cleaner and hydraulic oil filter
- Comprehensive overhead digital instrumentation display
- Generous storage space
- Regulated catalytic converter for LPG engine (3-way)
- LBR
- Engine air pre-cleaners
- 15.3 gal. diesel fuel tank capacity

Optional Equipment

- Single pedal with direction selector on armrest
- Integral sideshift
- Additional hydraulic circuits
- Weather protection alternatives up to fully enclosed cabin
- Screen wiper-washers for front, rear and roof screens
- Cab heating/air conditioning plus pollen filters
- Alternative seats
- Truck lighting and working lamps
- Clipboard, cab light
- Flashing amber beacon
- Audible reverse warning
- Mirrors
- Alternative paint

Check with dealer/factory for additional equipment availability.



Linde Lift Truck Corporation

2450 West 5th North Street

Summerville, SC 29483

Phone (843) 875-8000

Fax (843) 875-8380

Web Site: <http://www.lindelifttruck.com>

E-mail: trucksales@lindelifttruck.com

ANSI CLASSIFICATION: Standard truck meets all applicable mandatory requirements of ANSI/ASME B56.1 standards for powered industrial trucks.
NOTE: Performance data may vary due to motor and system efficiency tolerances. The performance depicted represents nominal values obtained under typical operating conditions. Metric dimensions are in millimeters unless otherwise specified. All metric dimensions are not direct equivalents due to rounding data. The descriptions and specifications included on this data sheet were in effect at the time of printing. Linde Lift Truck Corporation reserves the right to make improvements and changes in specification or design without notice and without incurring obligation. Please check with your authorized Linde dealer for information on possible updates or revisions.

Downrating Charts

**H40D/T (394) Capacity: Triplex Mast w/Std Carriage
250-15 SE Tires with 2"x5"x48" Forks**

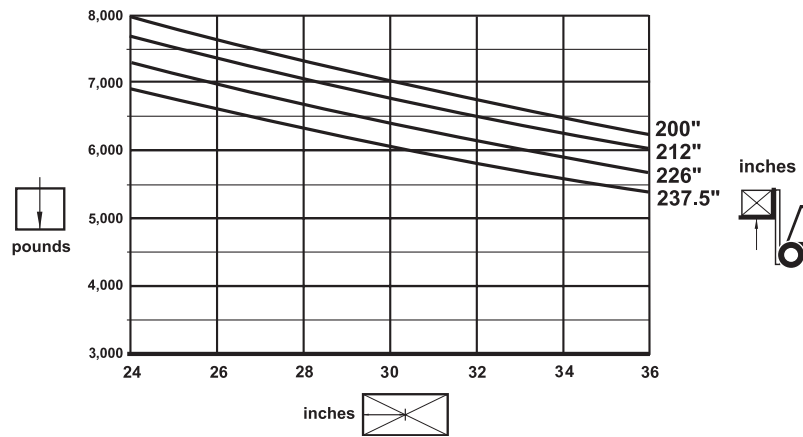

**H45D/T (394) Capacity: Triplex Mast w/Std Carriage
300-15 SE Tires with 2"x5"x48" Forks**

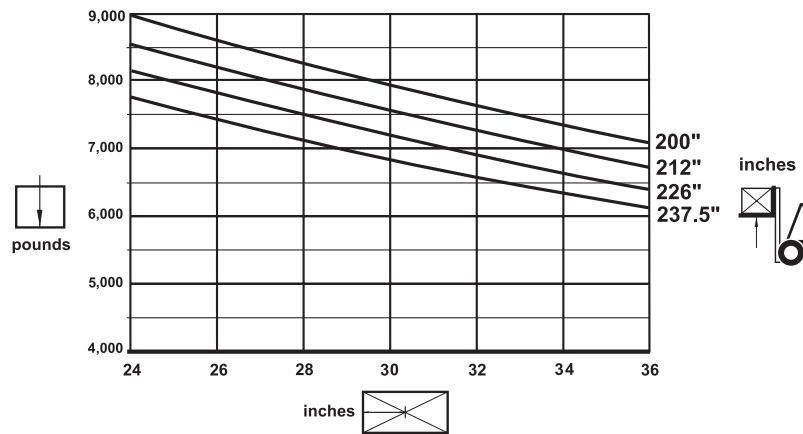

**H50D/T (394) Capacity: Triplex Mast w/Std Carriage
300-15 SE Tires with 2"x6"x48" Forks**

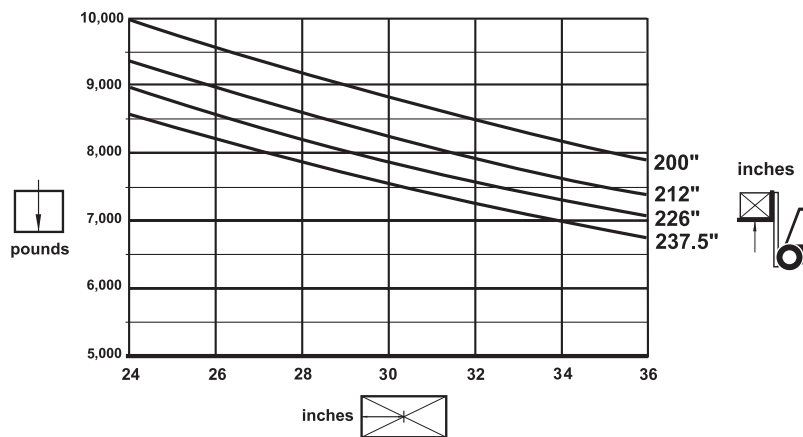

Contact manufacturer for additional downrating and capacity information.

**394 Series
H40D/T
H45D/T
H50D/T**

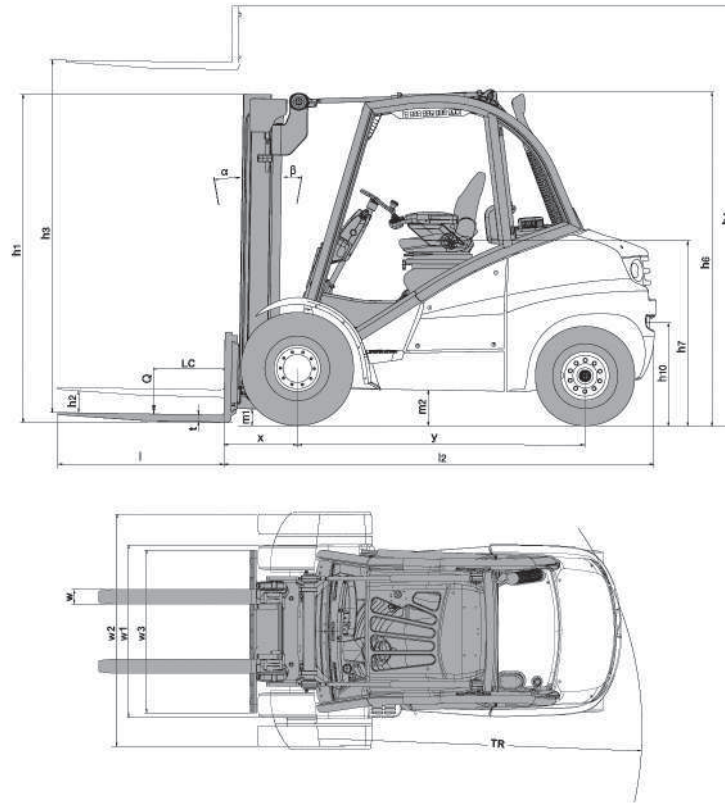

MAST AND CAPACITY INFORMATION H40D/T (SE Tires)

Type	Maximum Collapsed Height h1	Fork ¹ Height h3	Capacity lb(kg) Without Attachment		Free Lift h2		Tilt	
			H40D/H40T		With LBR	Without LBR	F	B
Simple	94.5 (2,400)	127.0 (3,225)	8,000 (4,000)		—	—	5°	9°
	98.5 (2,502)	135.0 (3,428)	8,000 (4,000)		—	—	5°	9°
	104.5 (2,654)	146.5 (3,741)	8,000 (4,000)		—	—	5°	9°
	110.0 (2,794)	158.5 (4,025)	8,000 (4,000)		—	—	5°	9°
Dual	95.5 (2,426)	128.0 (3,251)	8,000 (4,000)		45.5 (1,156)	65.5 (1,664)	5°	9°
	99.5 (2,527)	136.0 (3,454)	8,000 (4,000)		49.0 (1,245)	69.0 (1,753)	5°	9°
	105.5 (2,680)	147.5 (3,746)	8,000 (4,000)		55.0 (1,397)	75.0 (1,905)	5°	9°
	109.5 (2,781)	155.5 (3,949)	8,000 (4,000)		59.0 (1,499)	79.0 (2,007)	5°	9°
Triple	91.5 (2,324)	179.0 (4,546)	8,000 (4,000)		41.5 (1,054)	61.5 (1,562)	5°	9°
	93.5 (2,375)	185.0 (4,698)	8,000 (4,000)		43.5 (1,105)	63.5 (1,613)	5°	9°
	95.5 (2,426)	188.0 (4,775)	8,000 (4,000)		45.5 (1,158)	65.5 (1,664)	5°	9°
	99.5 (2,528)	200.0 (5,079)	8,000 (4,000)		49.0 (1,245)	69.0 (1,753)	5°	9°
	103.5 (2,629)	212.0 (5,384)	— (—)		53.0 (1,346)	73.0 (1,854)	—	—

MAST AND CAPACITY INFORMATION H45D/T, H50D/T (SE Tires)

Type	Maximum Collapsed Height h1	Fork ¹ Height h3	Capacity lb (kg) Without Attachment		Free Lift h2		Tilt	
			H45D/H45T	H50D/H50T	With LBR	Without LBR	F	B
Simple	95.0 (2,413)	123.0 (3,124)	9,000 (4,500)	10,000 (5,000)	—	—	5°	9°
	101.0 (2,565)	135.0 (3,428)	9,000 (4,500)	10,000 (5,000)	—	—	5°	9°
	107.0 (2,718)	146.5 (3,721)	9,000 (4,500)	10,000 (5,000)	—	—	5°	9°
	111.0 (2,819)	154.5 (3,924)	9,000 (4,500)	10,000 (5,000)	—	—	5°	9°
Dual	96.0 (2,438)	124.0 (3,149)	9,000 (4,500)	10,000 (5,000)	39.5 (1,003)	59.5 (1,511)	5°	9°
	102.0 (2,591)	136.0 (3,454)	9,000 (4,500)	10,000 (5,000)	45.0 (1,143)	65.0 (1,651)	5°	9°
	108.0 (2,743)	147.5 (3,746)	9,000 (4,500)	10,000 (5,000)	51.0 (1,294)	71.0 (1,803)	5°	9°
	112.0 (2,845)	155.5 (3,949)	9,000 (4,500)	10,000 (5,000)	55.0 (1,397)	75.0 (1,905)	5°	9°
Triple	94.5 (2,400)	179.0 (4,546)	9,000 (4,500)	10,000 (5,000)	37.5 (0953)	57.5 (1,461)	5°	9°
	96.0 (2,438)	185.0 (4,698)	9,000 (4,500)	10,000 (5,000)	39.5 (1,003)	59.5 (1,511)	5°	9°
	98.0 (2,450)	188.0 (4,775)	9,000 (4,500)	10,000 (5,000)	41.0 (1,041)	61.0 (1,549)	5°	9°
	102.0 (2,591)	200.0 (5,079)	9,000 (4,500)	10,000 (5,000)	45.0 (1,143)	65.0 (1,651)	5°	9°
	106.0 (2,692)	212.0 (5,384)	— (—)	— (—)	49.0 (1,245)	69.0 (1,753)	—	—

¹ For overall height raised (h4) with LBR add 48 in (1,220 mm)

Manufacturer's Data and Design Characteristics
January 2005

		Manufacturer	Linde	
Characteristics	1.1	Model Designation	H40D	H40T
	1.2	Load Capacity	Q lb (kg)	8,000 (4,000)
	1.3	Load Center	LC in (mm)	24 (500)
	1.4	Power Unit, Electric, Diesel, LP, Other		Diesel LP
	1.5	Operator Position, Walkie, Rider/Stand, Rider/Sitdown		Rider/Sitdown
	1.6	Tires F/R, C=Cushion; SE=Cushion Super Elastic; P=Pneumatic		P/P ¹
	1.7	Wheels, Front/Rear (x = driven)		2x/2 ²
	1.8	Steering, Power/Manual		Power
Dimensions	2.1	Simple Mast	in (mm)	See Mast Table
	2.2	Dual Mast	in (mm)	See Mast Table
	2.3	Triple Mast	in (mm)	See Mast Table
	2.4	Fork Carriage, Class/Width	w3 in (mm)	III/53.1 (III/1,350)
	2.5	Fork Dimensions	t x l x w in (mm)	2x42x5 (50x1,067x127)
	2.6	Load Backrest Height	LBR in (mm)	48 (1,219)
	2.7	Forward/Backward Tilt	degrees	5.0/9.0
	2.8	Total Length to Fork face	l2 in (mm)	117.5 (2,984)
	2.9	Overall Width, (Front)	w1 in (mm)	56.9 (1,446)
	2.10	Chassis Width, With Dual Tires	w2 in (mm)	78.1 (1,984)
	2.11	Front Overhang	x in (mm)	19.0 (483)
	2.12	Truck Height Including Overhead Guard	h6 in (mm)	93.8 ⁴ (2,383) ⁴
	2.13	Seat Height	h7 in (mm)	48.3 (1,226)
	2.14	Turning Radius	TR in (mm)	105.2 (2,672)
	2.15	Aisle Width	in (mm)	124.2 ³ (3,155) ³
	2.16	Tow Bar Height	h10 in (mm)	27.7 (703)
Performance	3.1	Travel Speed With/Without Load	mph (kmh)	13.0/13.0 (21.0/21.0)
	3.2	Lifting Speed With/Without Load	fpm (mps)	104.3/110.0 (0.53/0.56)
	3.2	Lowering Speed With/Without Load	fpm (mps)	102.0/112.0 (0.52/0.57)
	3.4	Drawbar Pull With/Without Load	lb (N)	6,422/4,628 (28,541/20,570)
	3.5	Gradeability With/Without Load	%	34.5/34.0
Weight	4.1	Weight	lb (kg)	12,665 (5,745)
	4.2	Axle Loading With Load, Front/Rear	lb (kg)	18,197/2,468 (8,608/1,137)
	4.3	Axle Loading Without Load, Front/Rear	lb (kg)	5,820/6,845 (2,640/3,105)
Chassis	5.1	Tire Size, Front		250-15/18PR IC40
	5.2	Tire Size, Rear		250-15/18PR IC40
	5.3	Wheelbase	y in (mm)	78.7 (1,998)
	5.4	Track Width Center Line of Drive Tires, (single & dual drive)	in (mm)	48.1/59.0 (1,221/1,499)
	5.4	Track Width Rear Tires	in (mm)	44.2 (1,123)
	5.6	Ground Clearance With Load (Mast)	m1 in (mm)	6.2 (158)
	5.7	Ground Clearance With Load (Chassis)	m2 in (mm)	7.9 (201)
	5.8	Brake System		Dynamic/Hydraulic
	5.9	Parking Brake		Foot/Hand
Drive	6.1	Voltage (Electrical System)	v	12
	6.2	Engine Manufacturer/Type/Cyl.		VW/BJC 4 Cyl. VW/BMF 6 Cyl.
	6.3	Engine Rating	hp (kw)	71(53) 74(55)
	6.4	Engine RPM	max. rpm	2,800
	6.5	Engine Displacement	cu. in (cc)	116(1,896) 194(3,189)
	6.6	Transmission		Hydrostatic
Other	7.1	Noise Level (With Cab.)	dBa	77.5 /74.0
	7.2	Speed Control		Infinitely Variable
	7.3	Hydraulic Operating Pressure For Attachments	psi (bar)	2,465 (170)

¹ SE tires optional.

³ Plus load length plus clearance for 90° stack.

² Dual drive tires optional.

⁴ Plus 2.0 Inches (50MM) with top glass wiper.



Linde		Linde	
H45D	H45T	H50D	H50T
9,000	(4,500)	10,000	(5,000)
24	(500)	24	(500)
Diesel	LP	Diesel	LP
Rider/Sitdown		Rider/Sitdown	
SE/SE		SE/SE	
2x/2 ²		2x/2 ²	
Power		Power	
See Mast Table		See Mast Table	
See Mast Table		See Mast Table	
See Mast Table		See Mast Table	
III/53.1	(III/1,350)	III/53.1	(III/1,350)
2x42x5	(50x1,067x127)	2x42x6	(50x1,067x152)
48	(1,219)	48	(1,219)
5.0/9.0		5.0/9.0	
120.7	(3,066)	122.7	(3,116)
57.0	(1,448)	57.0	(1,448)
78.1	(1,984)	78.1	(1,984)
20.7	(525)	21.1	(535)
95.1 ⁴	(2,416) ⁴	95.1 ⁴	(2,416) ⁴
49.8	(1,264)	49.8	(1,264)
106.6	(2,708)	108.0	(2,745)
127.3 ³	(3,233) ³	129.1 ³	(3,280) ³
28.6	(726)	28.3	(719)
14.9/14.9	(24.0/24.0)	14.9/14.9	(24.0/24.0)
104.3/110.0	(0.53/0.56)	94.5/98.5	(0.48/0.50)
102.0/112.0	(0.52/0.57)	98.5/110.0	(0.50/0.56)
5,690/4,914	(25,285/21,841)	5,689/5,034	(25,285/22,375)
23.5/32.0		22.6/31.8	
13,977	(6,340)	14,506	(6,580)
20,168/2,809	(9,555/1,285)	21,862/2,645	(10,371/1,209)
6,155/7,822	(2,792/3,548)	6,349/8,157	(2,880/3,700)
300-15 SE		300-15 SE	
250-15 SE		250-15 SE	
80.2	(2,038)	81.8	(2,078)
48.1/59.0	(1,190/1,499)	48.1/59.0	(1,190/1,499)
44.2	(1,123)	44.2	(1,123)
8.0	(205)	8.0	(203)
9.3	(236)	9.3	(235)
Dynamic/Hydraulic		Dynamic/Hydraulic	
Foot/Hand		Foot/Hand	
12		12	
VW/BJC 4 Cyl.	VW/BMF 6 Cyl.	VW/BJC 4 Cyl.	VW/BMF 6 Cyl.
71(53)	74(55)	71(53)	74(55)
2,800		2,800	
116(1,896)	194(3,189)	116(1,896)	194(3,189)
Hydrostatic		Hydrostatic	
77.5 /74.0		77.5 /74.0	
Infinitely Variable		Infinitely Variable	
2,465	(170)	2,465	(170)